

FFI Forsvarets
forskningsinstitutt

Master assignments in UGV and robotics

Kim Mathiassen

We have two research vehicles



Olav, purchased 2015



Tor, purchased 2019



Autonomy Architecture

Motion planning

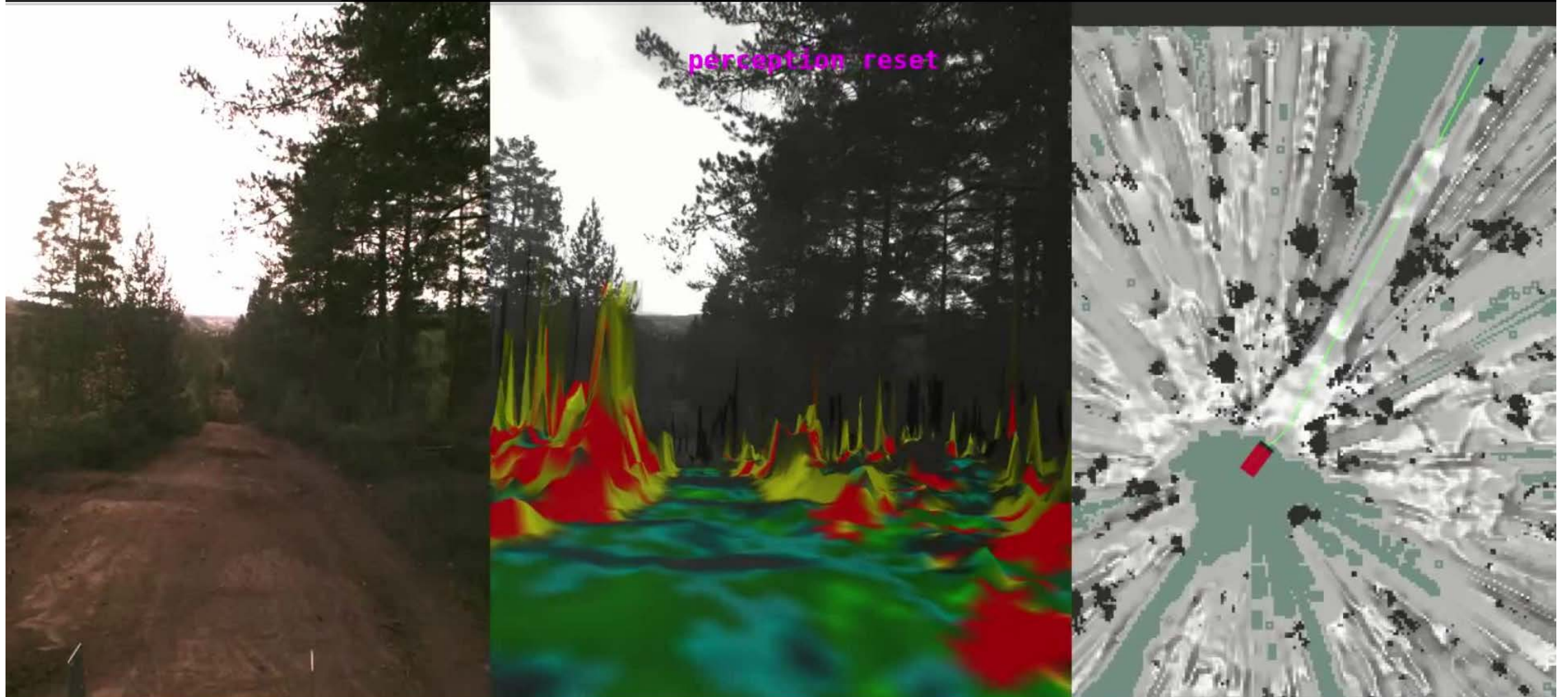

Unmanned Ground Vehicles – Master assignments

- Low level control of actuators
- Trajectory planning
- Trajectory tracking
- Motion planning
- Modeling of dynamic systems
- System identification
- State estimation
- Navigation and localization

- Higher lever decision making
- Perception

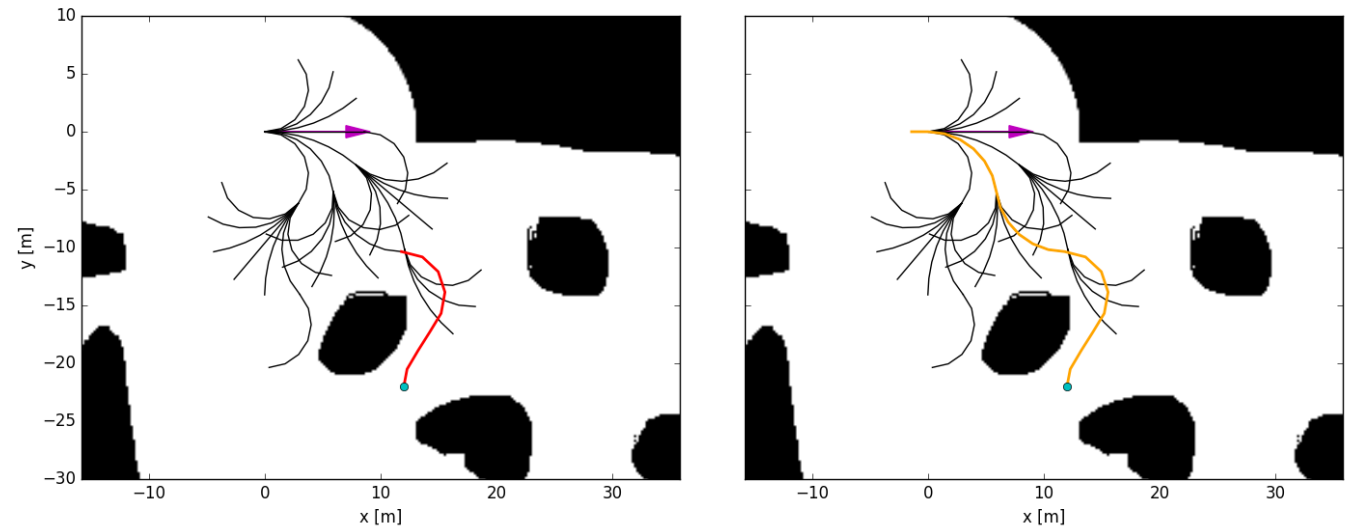
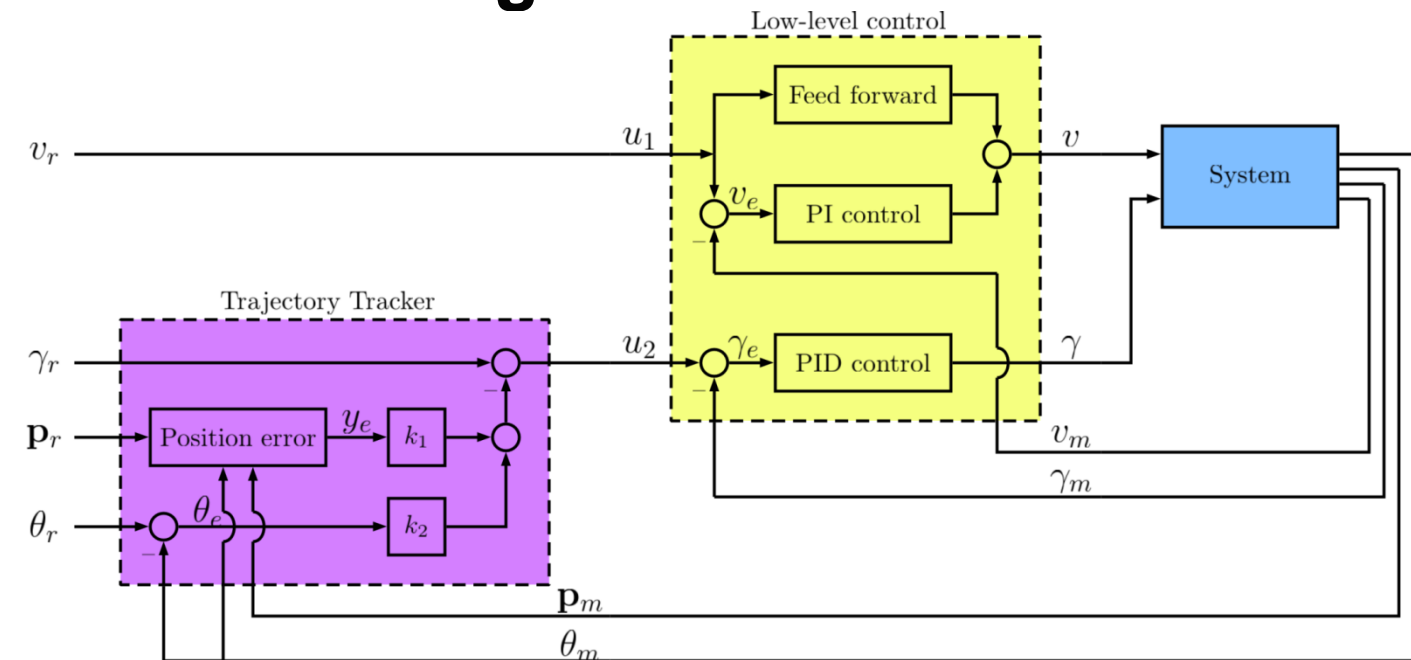

Control of Robots (TEK4030) – Master assignments

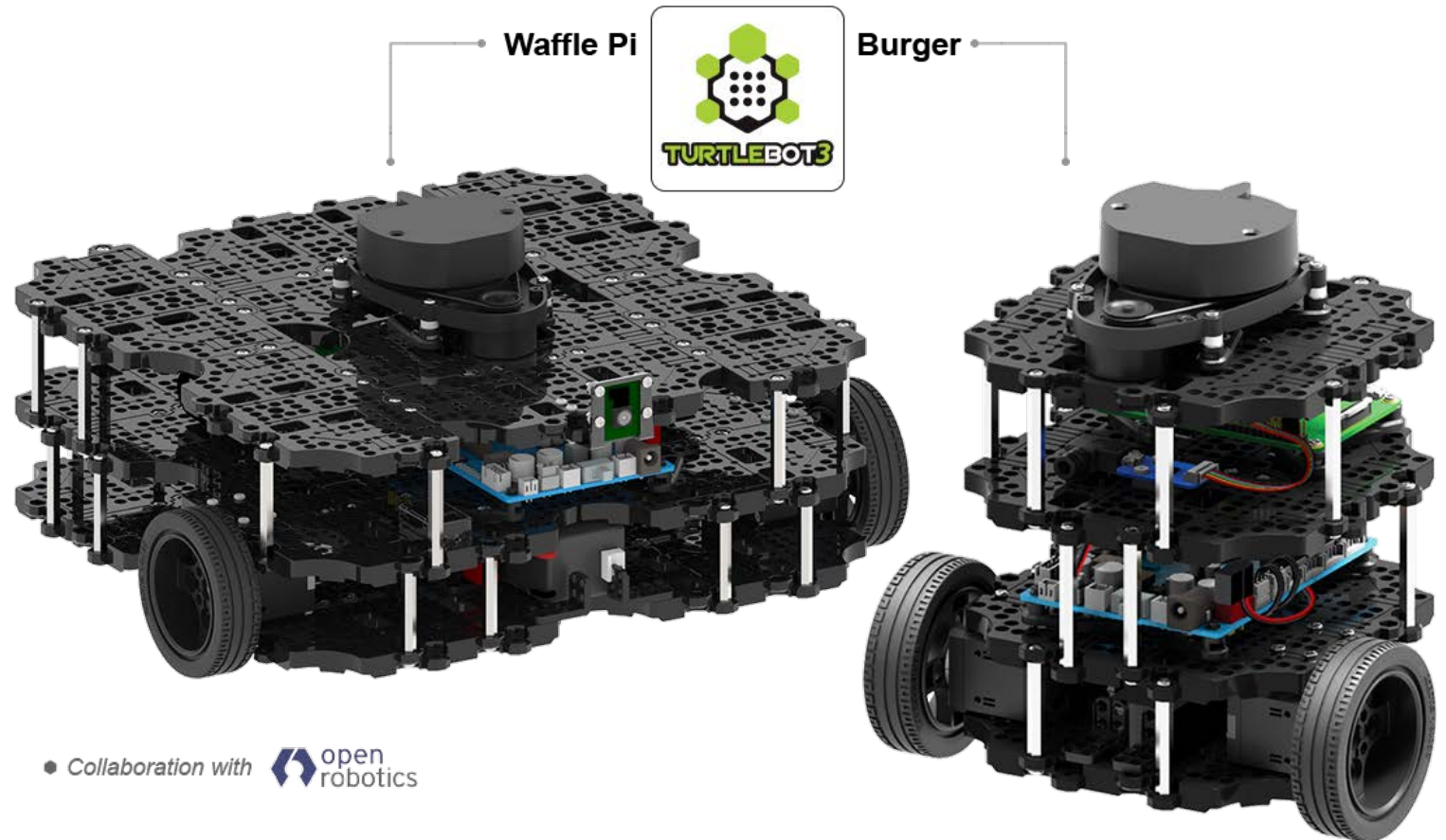

Takk for meg

