

Proton Ceramic Steam Electrolysers

Einar Vøllestad¹, R. Strandbakke¹, Dustin Beeff² and
T. Norby¹

¹University of Oslo, Department of Chemistry, ²CoorsTek Membrane Sciences AS



- Theoretical considerations on proton ceramic electrolysis operation
- Development and performance of tubular Proton Ceramic Electrolysers (PCEs)

Literature data for Proton Ceramic Electrolysers (PCEs)

Key question:

What is the origin of the low faradaic efficiencies observed in many PCEs?

Electrolyte	Anode	Temperature	i (mA cm ²)	ASR (Ω cm ²)	η (%)	Ref
SSY54I	SSC	600	100	4	~80	Matsumoto, 2012
BCZY53-Zn	BSCF	800	55	20	50	Li, 2013
BZCY72	LSCF	700	100	6	50	Babiniec, 2015
BCZY53-Zn	LSCM- BCZYZ	700	2000	6-8	22	Gan, 2012
BCZY62	BSCF	600	1050	0.5	99 (?)	Yoo, 2013
BCZY53	SSC-BCZY	700	400	1	-	He, 2010

Degradation and decomposition in H₂O



Operating Principles of Proton Ceramic Electrolysers (PCEs)

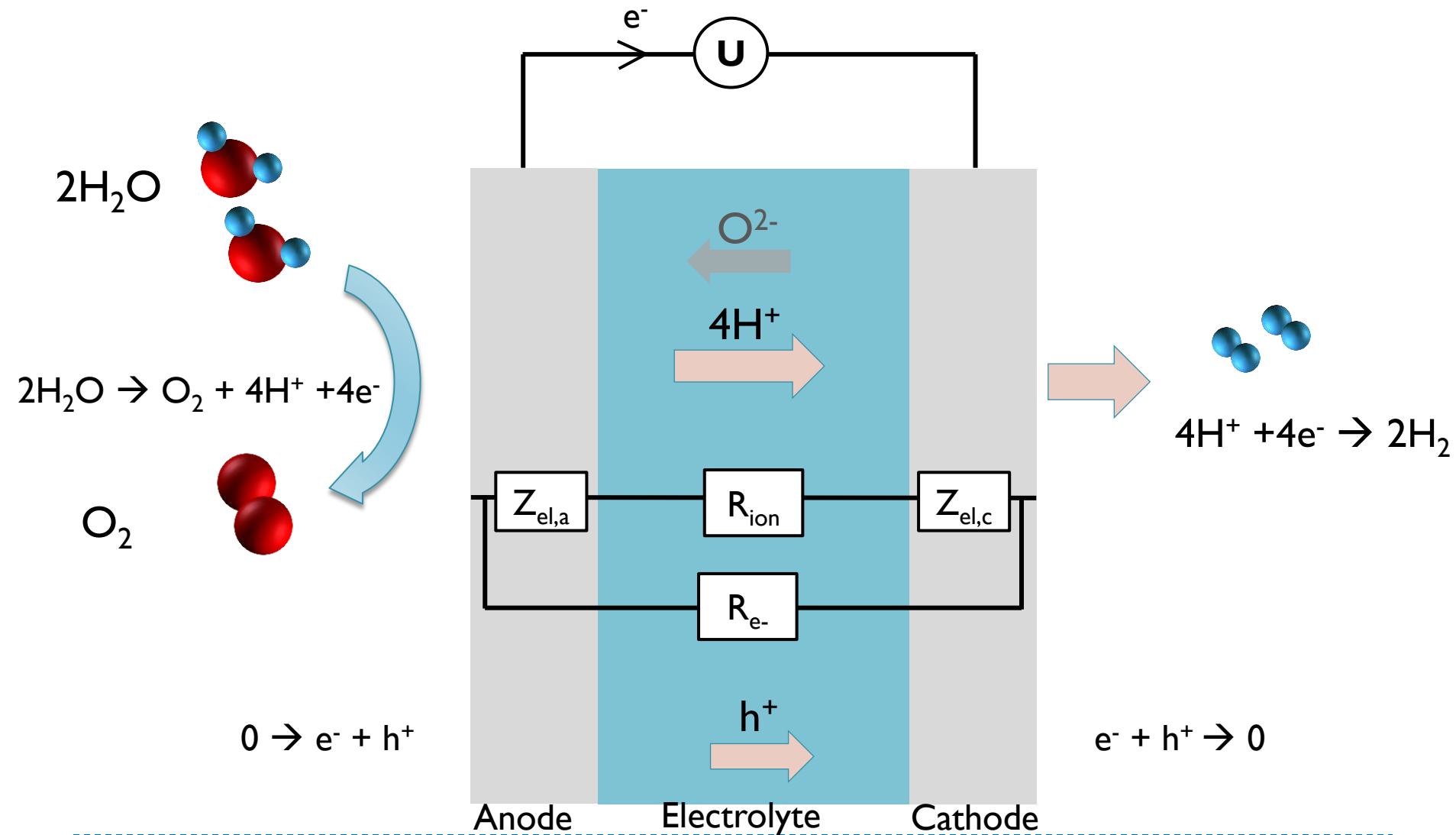

Potentials through a solid oxide electrolyser

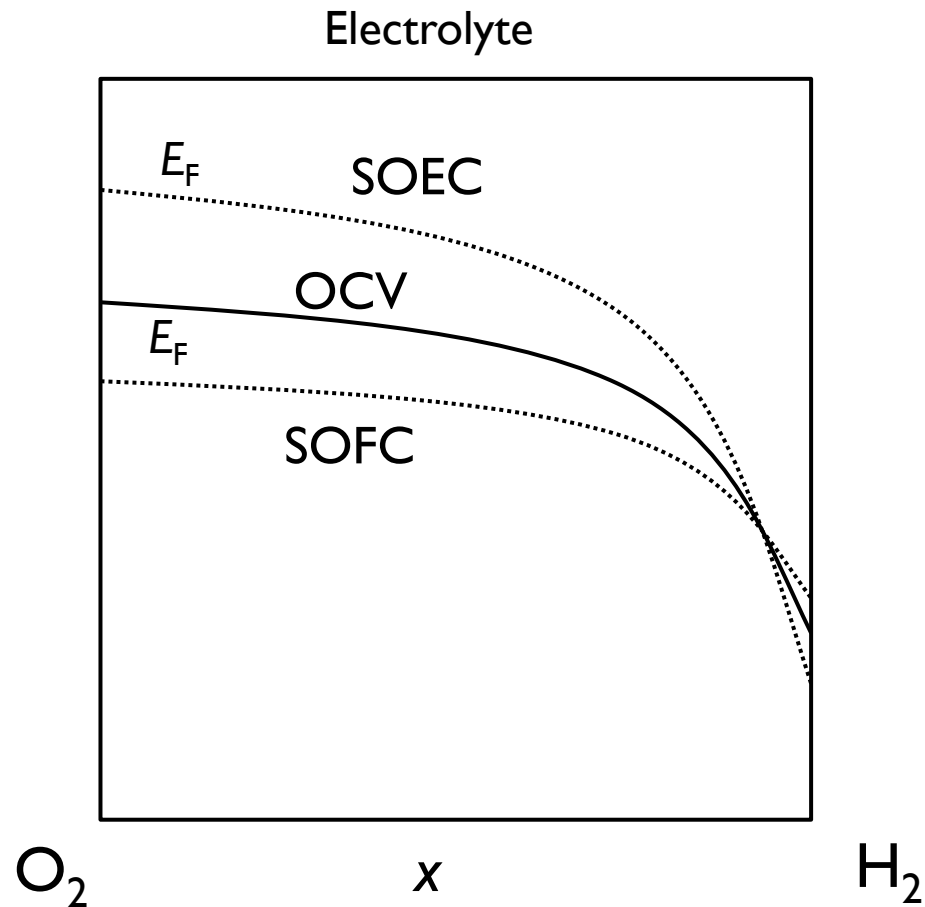

Electronic conductivity distribution during PCE operation

$$\sigma_p \propto pO_2^{1/4} \propto \exp(E_F/4)$$

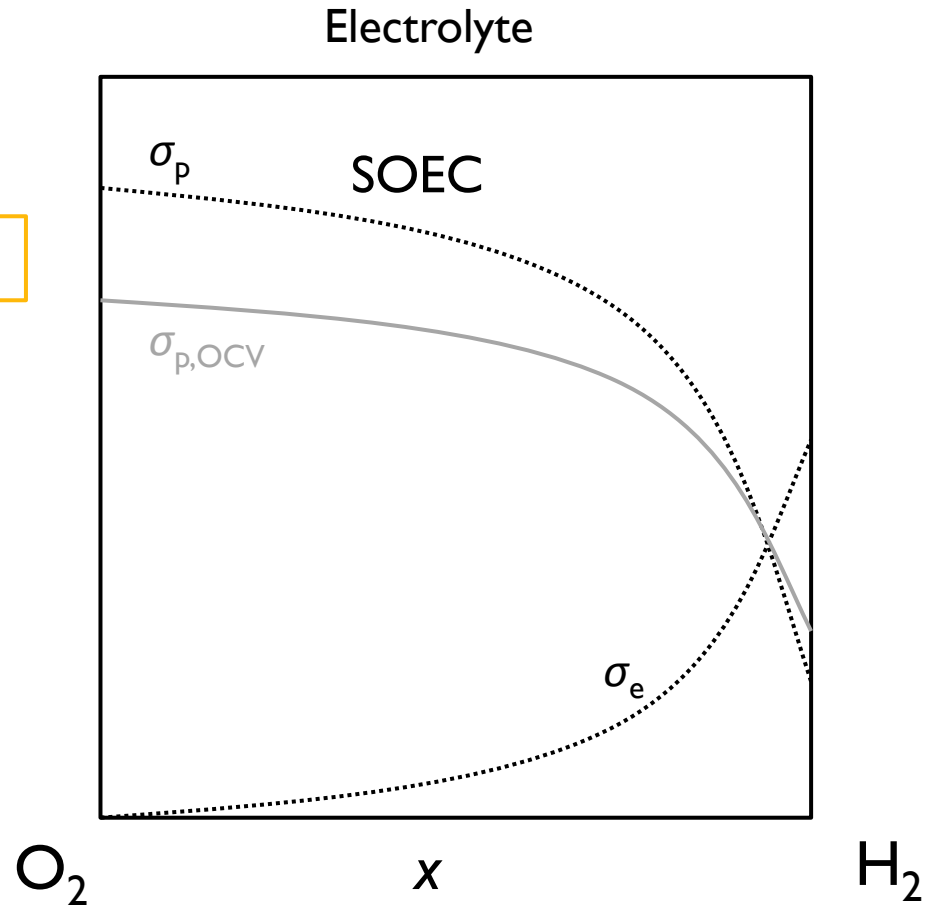

The effect of partial electronic conductivity on faradaic efficiency

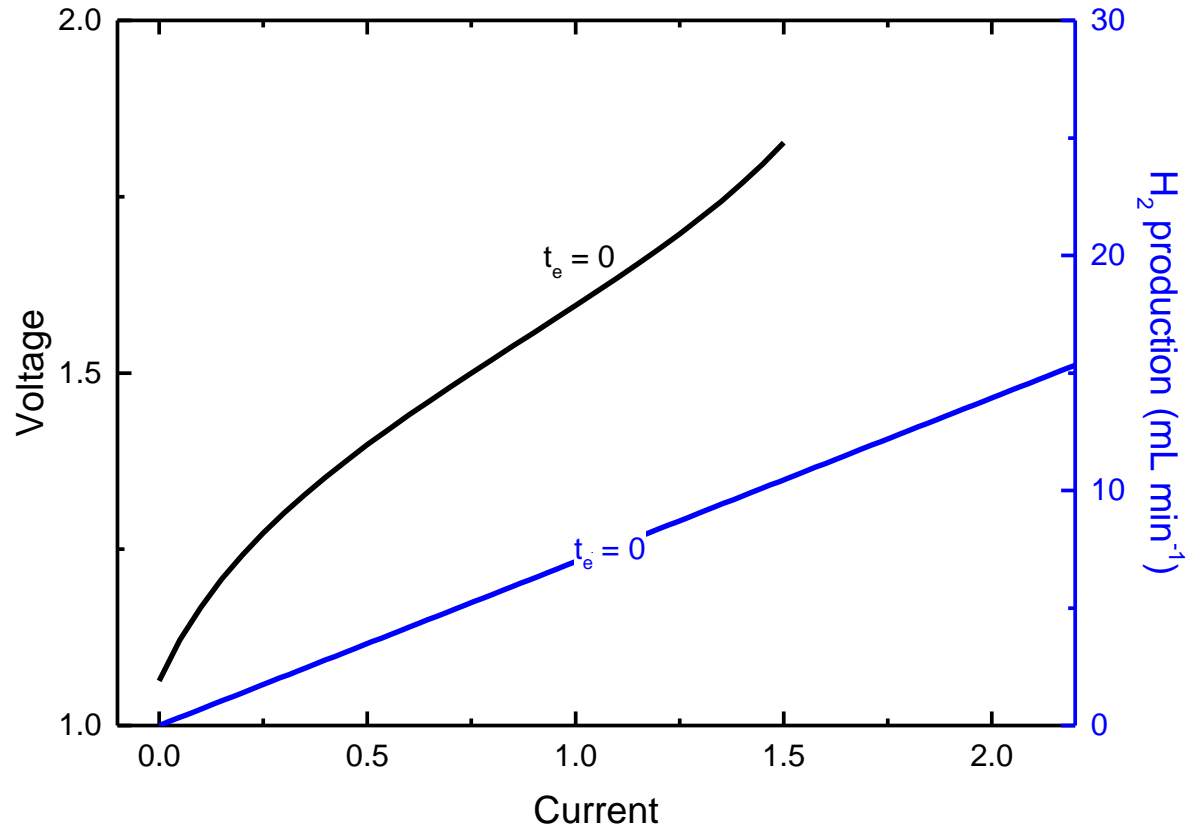

The effect of partial electronic conductivity on faradaic efficiency

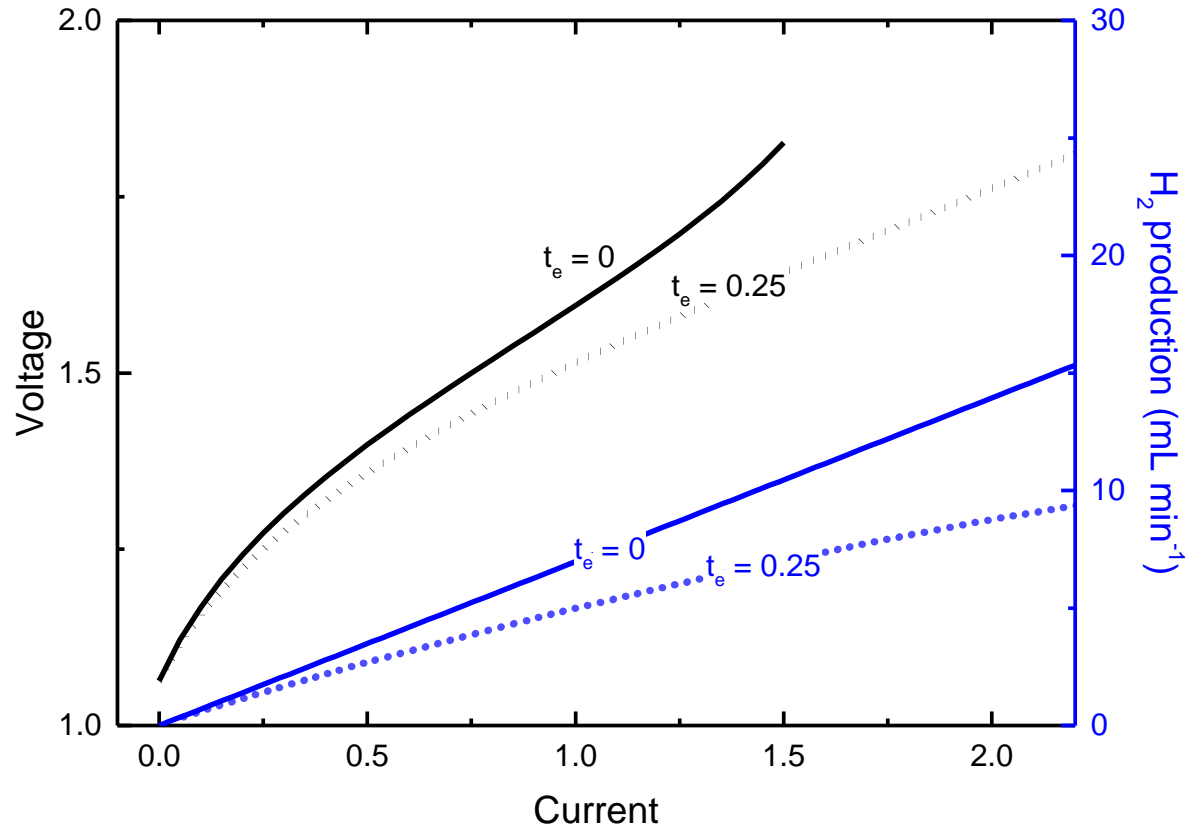

The effect of partial electronic conductivity on faradaic efficiency

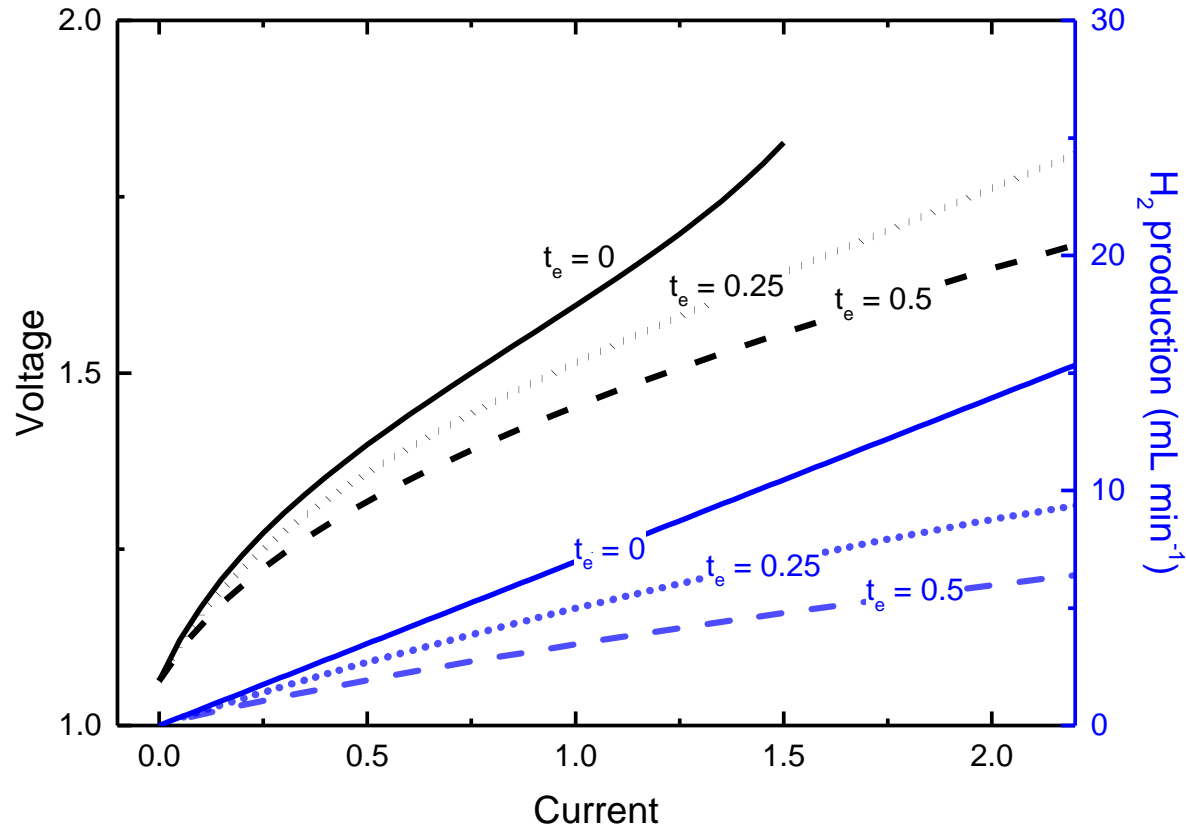

Electrode performance and steam content significantly influence faradaic efficiency

Anode dependence for with fixed $t_H = 0.8$

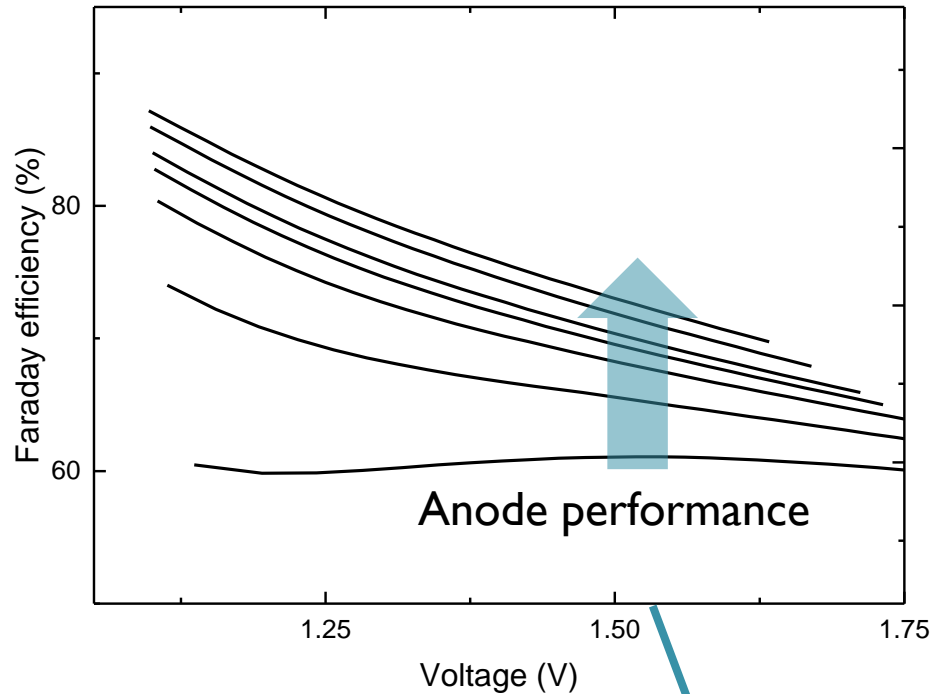

Steam content dependence with fixed $t_H = 0.8$

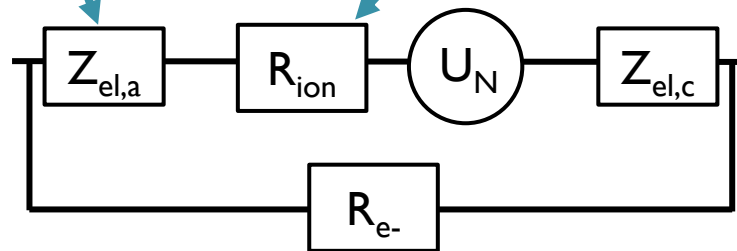
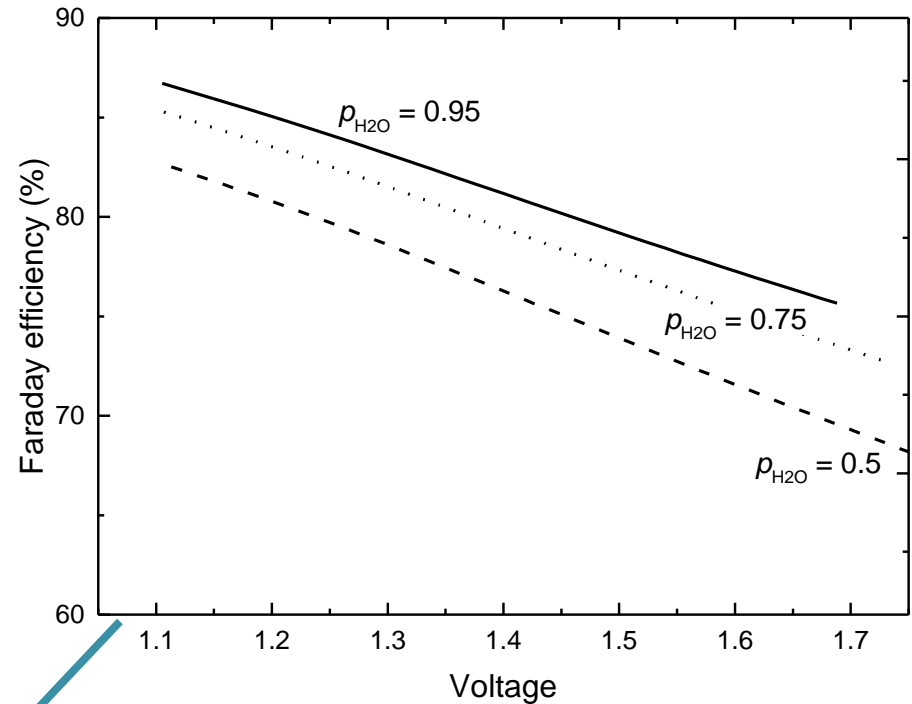



Tubular half-cell production

Wet milling of precursors

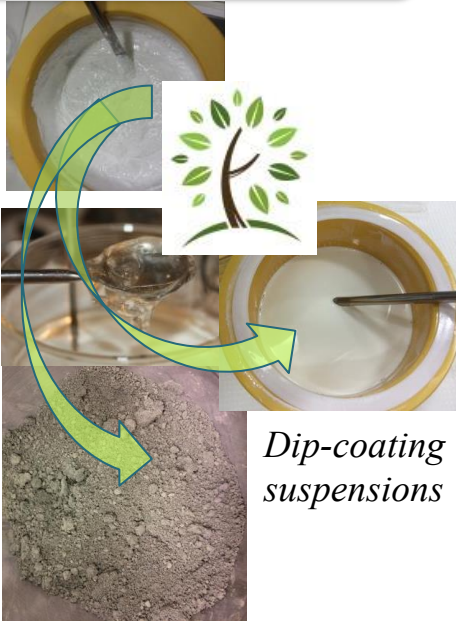

Dip-coating suspensions

NiO based paste

Extrusion of BZCY72-NiO support



Spray-coating BZCY72 electrolyte

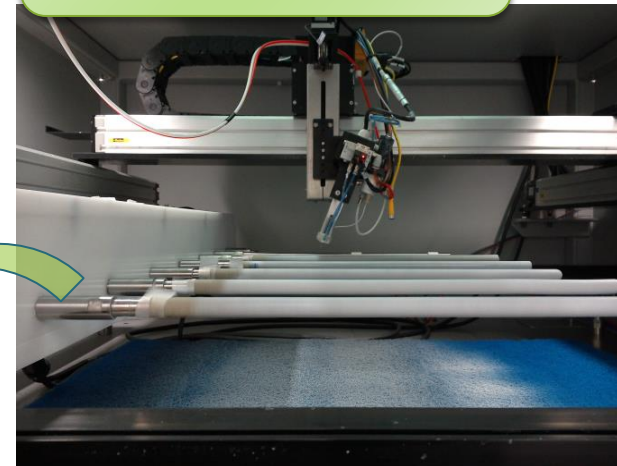

Solid State Reactive Sintering

Dense tubular half-cells achieved

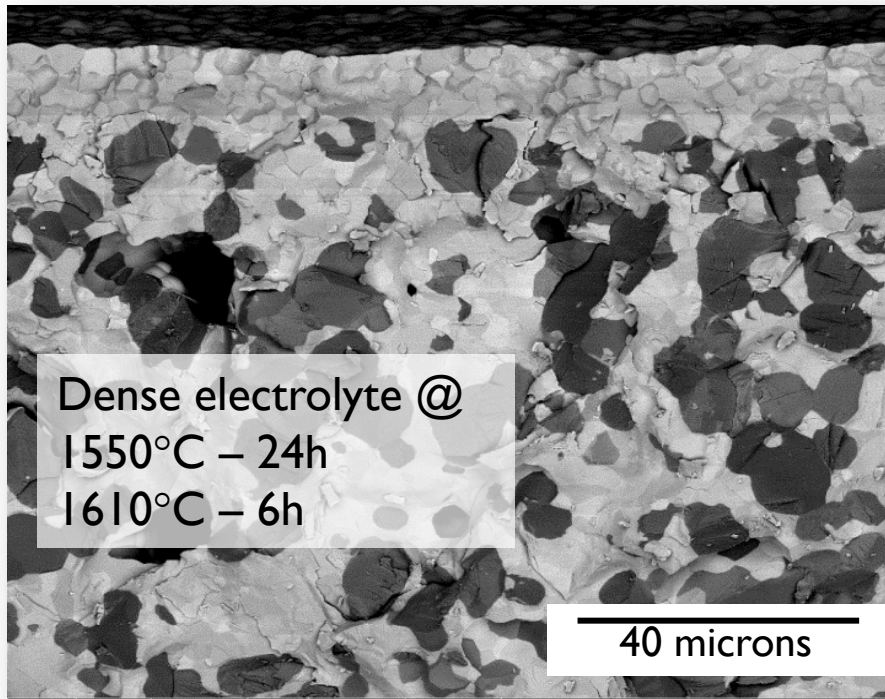

Steam electrode: $\text{Ba}_{1-x}\text{Gd}_{0.8}\text{La}_{0.2+x}\text{Co}_2\text{O}_{6-\delta}$

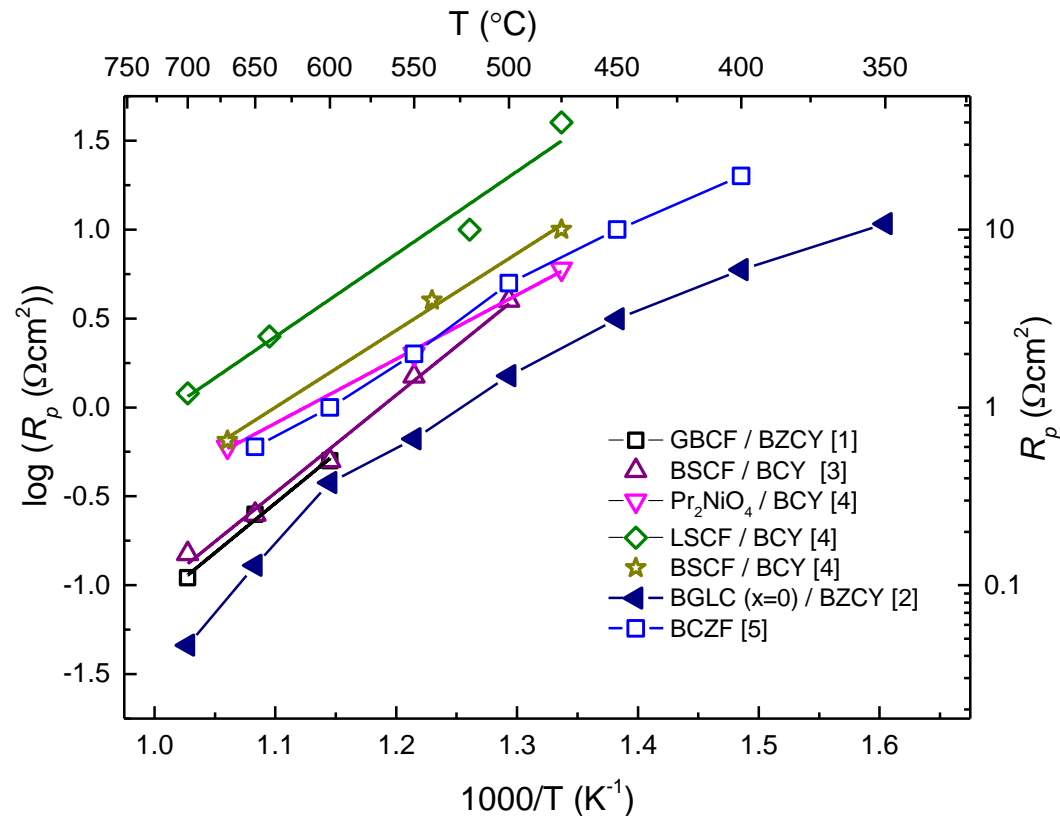

- 1: H. Ding et al., International Journal of Hydrogen Energy (2010).
- 2: R. Strandbakke et al., Solid State Ionics (2015).
- 3: Y. Lin et al., Journal of Power Sources (2008).
- 4: J. Dailly et al., Electrochimica Acta (2010).
- 5: M. Shang et al., RSC Advances, (2013)



Steam electrode processing on reduced tubes

1. Cap and seal segment using glass ceramic from CoorsTek
2. Deposit $\text{Ba}_{0.7}\text{Gd}_{0.8}\text{La}_{0.5}\text{Co}_2\text{O}_{6-\delta}$ as steam electrode by paint brush
3. Firing in dual atmosphere:
 - 1000°C
 - 2% O_2 outside, 5% H_2 inside
 - $E_{\text{cell}} = 1.4 \text{ V}$ during firing
4. Gold paste applied as current collector

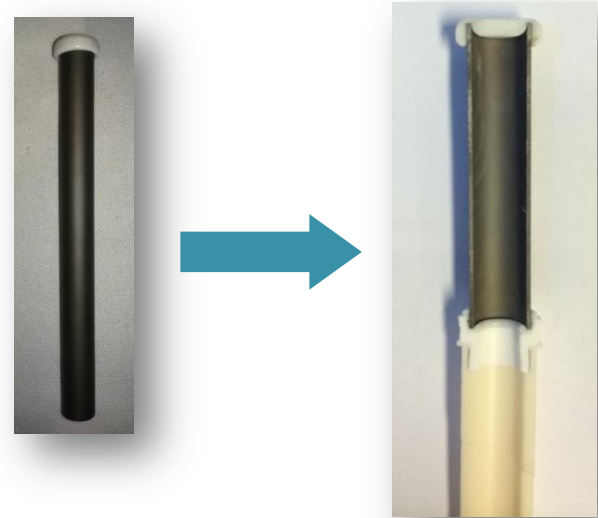

Cell 1
Area: 5 cm^2

Electrolysis with single phase BGLC electrode

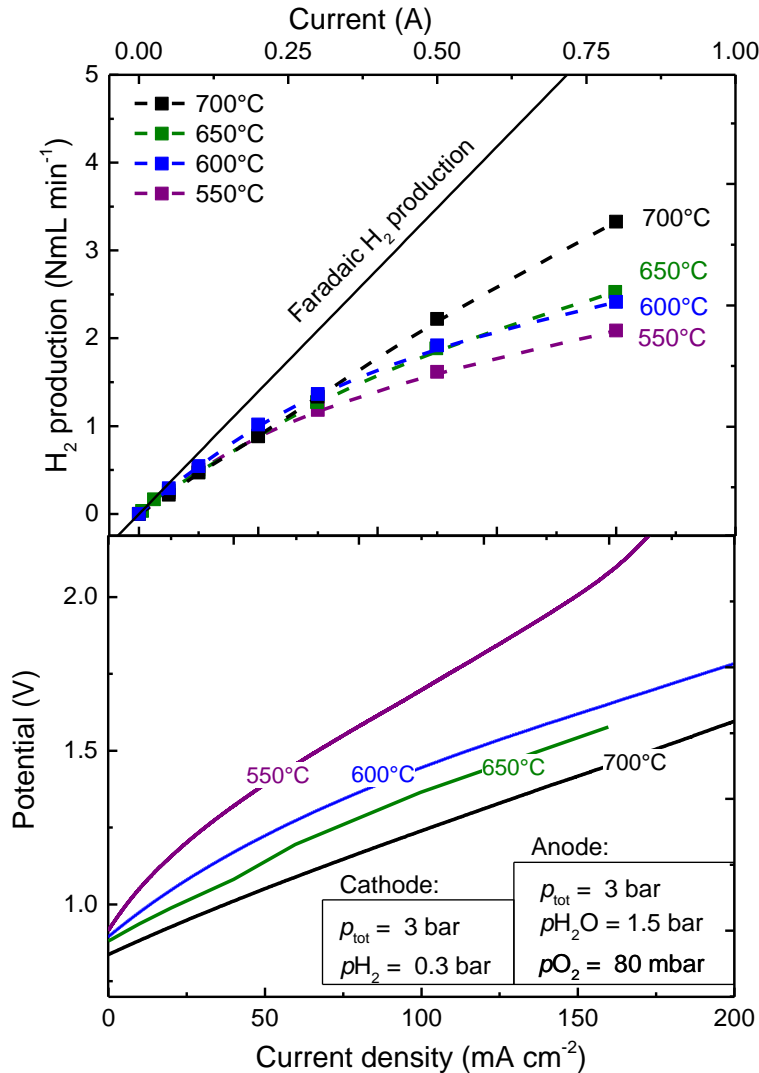

Faradaic efficiencies vs cell potential

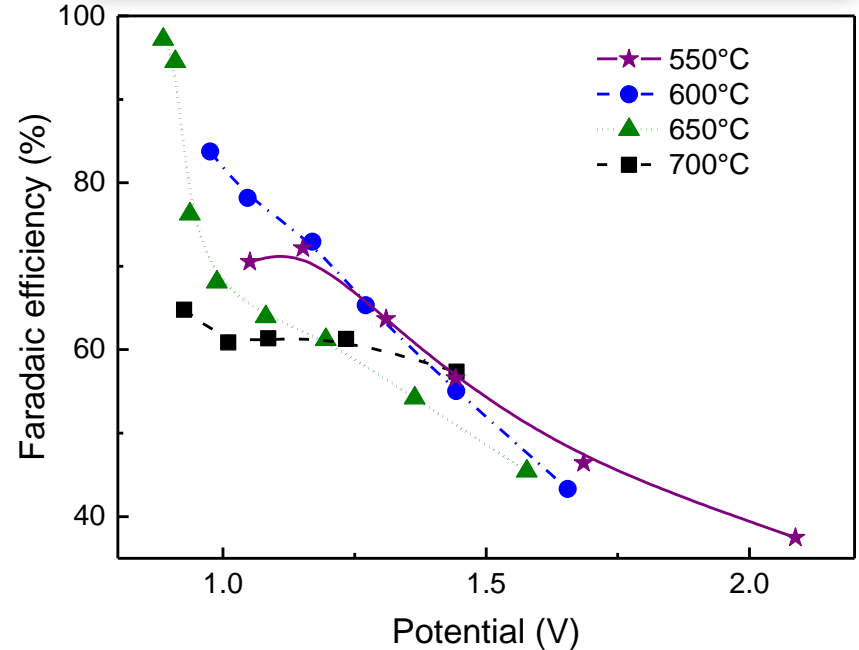

Electrolysis with single phase BGLC electrode

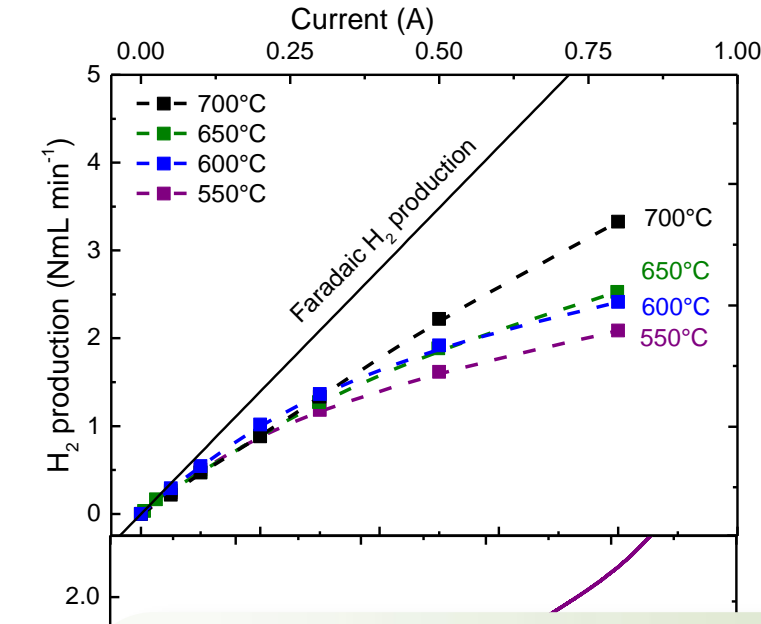

Impedance at 600°C for increasing galvanostatic bias

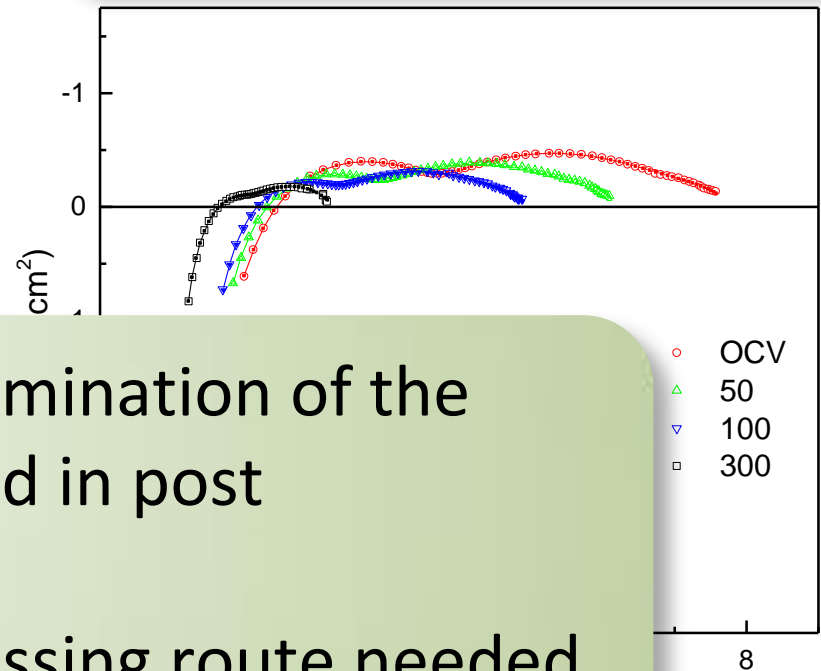

Poor adhesion and delamination of the electrode layer observed in post characterization

- Improved processing route needed

Current density (mA cm⁻²)



Steam electrode processing on unreduced tubes

1. BZCY72- $\text{Ba}_{0.5}\text{Gd}_{0.8}\text{La}_{0.7}\text{Co}_2\text{O}_{6-\delta}$ applied as steam electrode
 - Fired in air at 1200°C for 5h
 - Infiltrated with nanocrystalline $\text{Ba}_{0.5}\text{Gd}_{0.8}\text{La}_{0.7}\text{Co}_2\text{O}_{6-\delta}$
 - Thin Pt layer current collection
2. Capped and sealed at 1000°C
 - Semi-dual atmosphere to keep BGLC layer intact
3. NiO reduction at 800°C in 10% H_2 for 24h
 - Kept in electrolytic bias during reduction to avoid re-oxidation

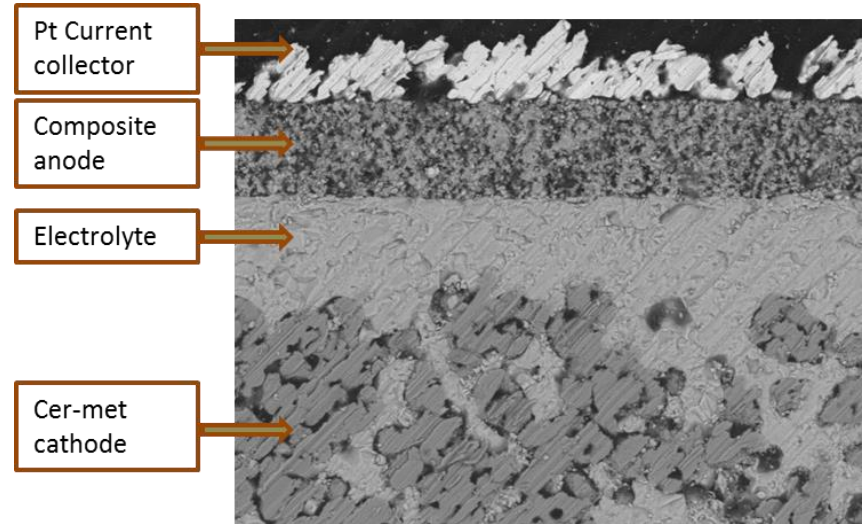

Electrolysis with composite BZCY-BGLC electrode

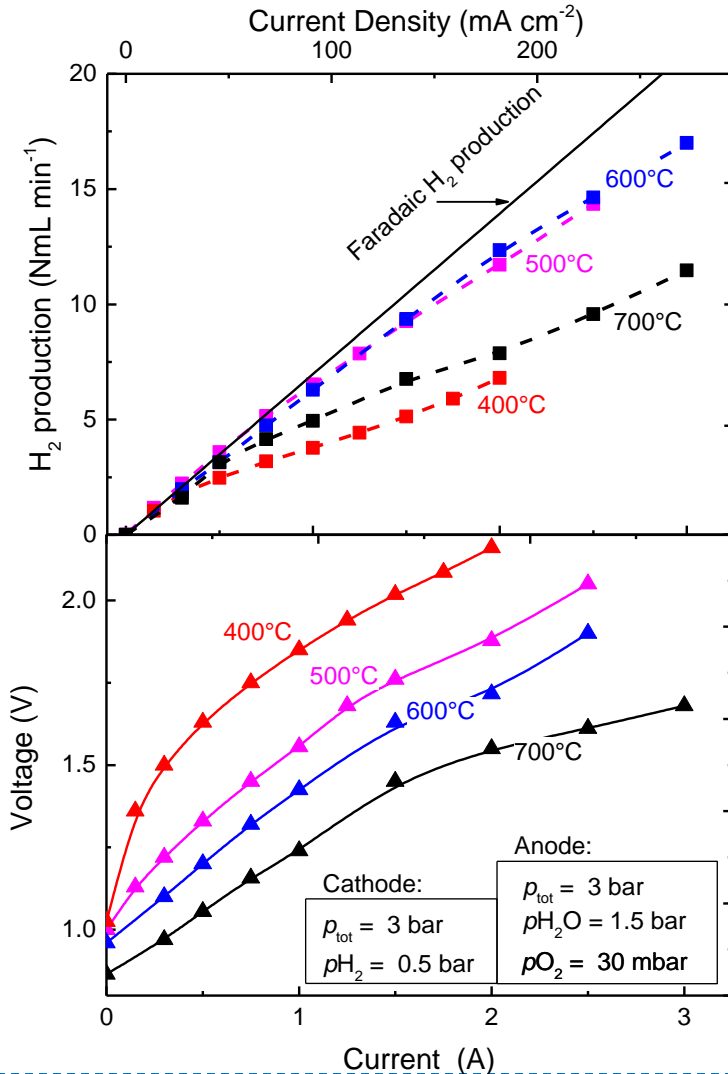

EIS at 300mA galvanostatic operation

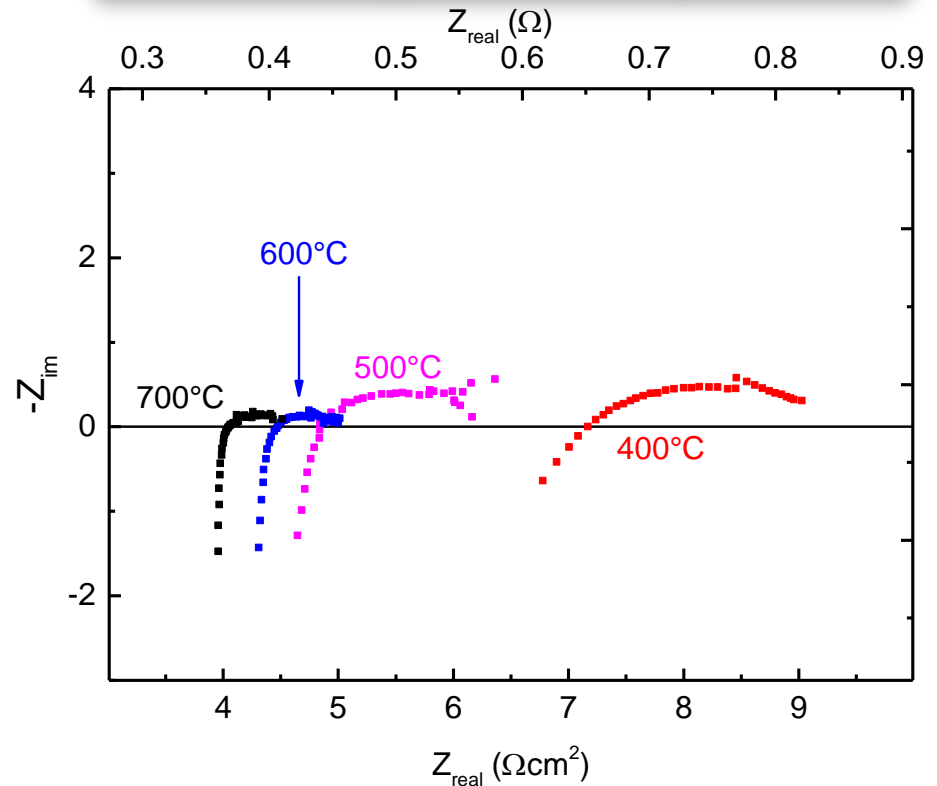

Electrolysis with composite BZCY-BGLC electrode

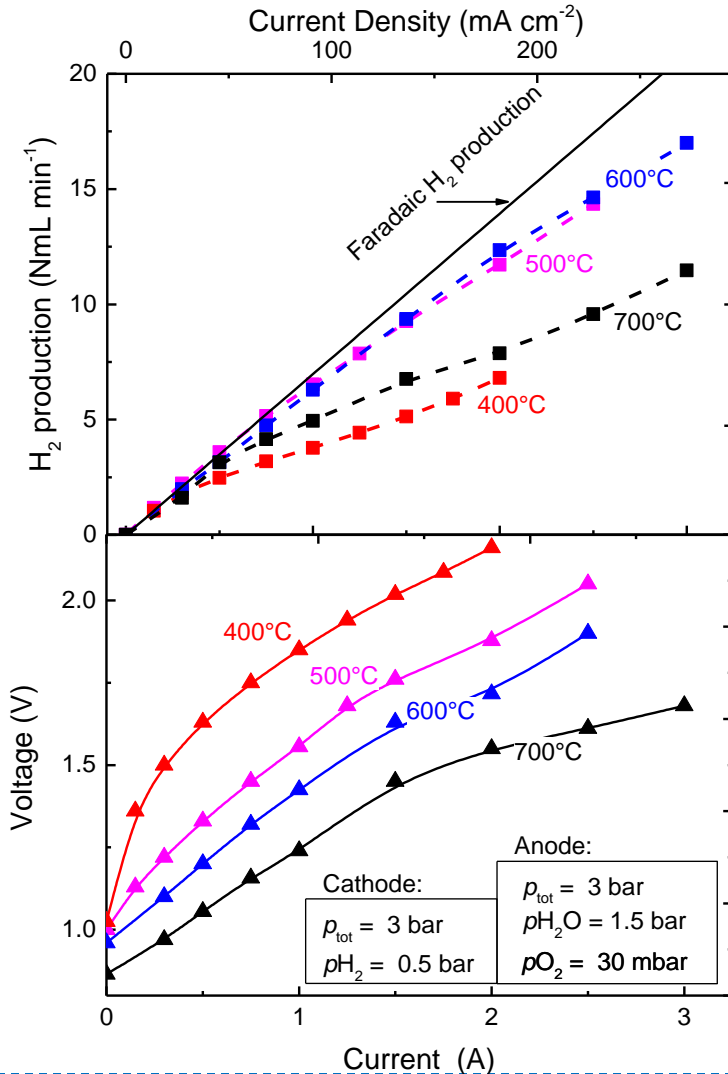

Calculated ASR from IV curves

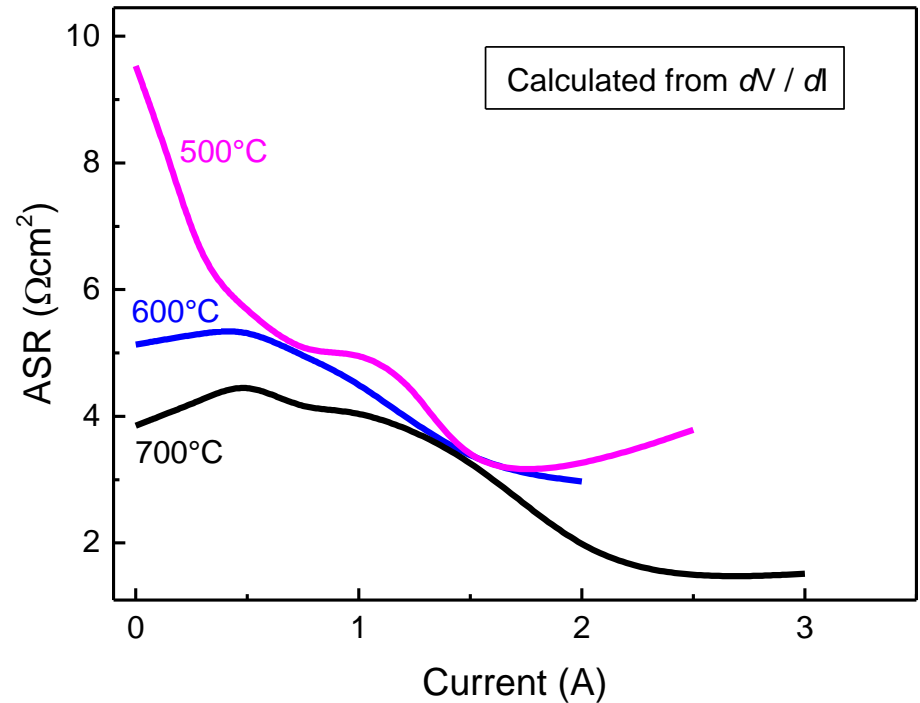

Improved faradaic efficiency primarily due to enhanced electrode kinetics

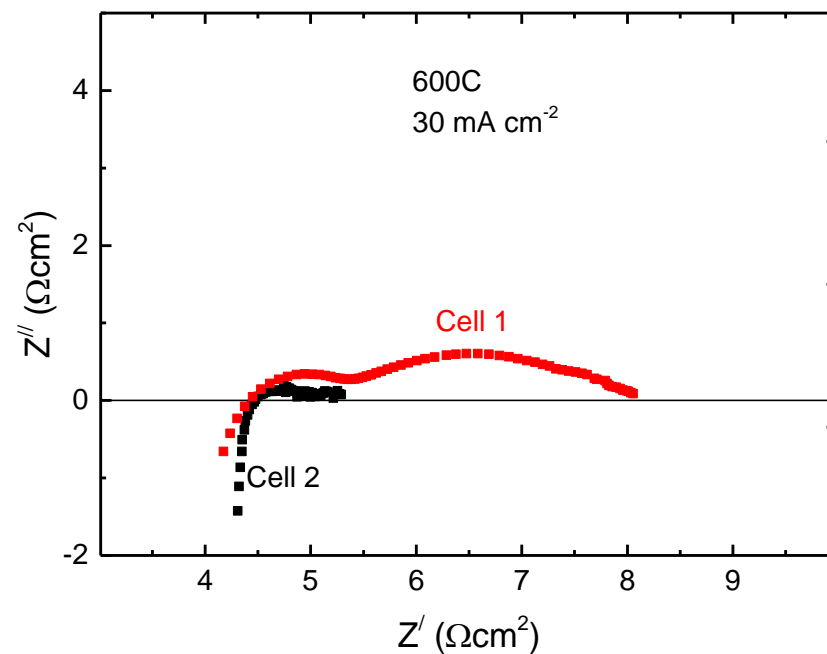
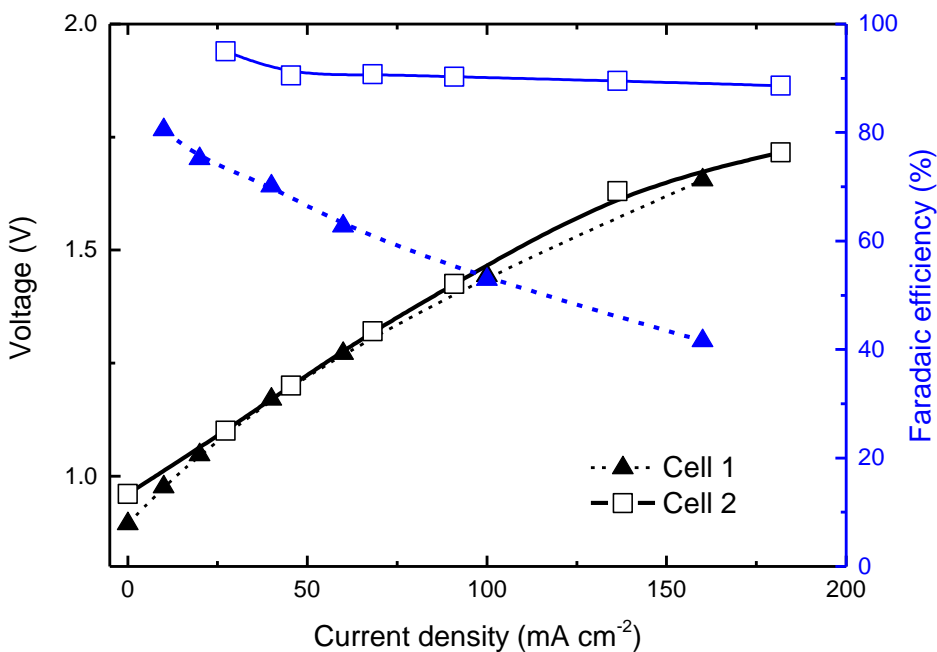

Conclusions

- ▶ Proton Ceramic Electrolysers may suffer from electronic leakage during operation due to relatively high p-type conductivity in oxidizing conditions
 - ▶ Operation at **high overpotentials** will induce **higher electronic conductivity** within the electrolyte material
 - ▶ Improved **electrode performance** and **higher steam pressures** may reduce electronic leakage

- ▶ Tubular PCEs were made based on BZCY-NiO tubular supports, spray coated BZCY72 electrolytes and BGLC steam electrodes
 - ▶ **Enhanced faradaic efficiencies** observed with improved anode performance
 - ▶ Current densities of **220 mA cm⁻² at 600°C** observed with **> 80% faradaic efficiency**
 - ▶ Contact resistance may still contribute significantly to the ohmic resistance of the electrolyser



Acknowledgements



The research leading to these results has received funding from the European Union's Seventh Framework Programme (FP7/2007-2013) for the Fuel Cells and Hydrogen Joint Technology Initiative under grant agreement n° 621244.

